



ALTO

Coworking

Mobility, flexibility and ergonomics have become essential criteria in work spaces.

The **Alto** coworking solutions propose innovating, comfortable and practical options to organise your meeting spaces and are ideal to develop relations between employees. Mobile workstations and their accessories (storage compartments, whiteboard, bag hook, extensions) as well as rectangular or square high tables combine ergonomics, built-in connections and contemporary look to create friendly and efficient collaborative atmospheres in your spaces. The **Alto** solutions meet all your layout requirements (lounge, meeting, coworking or project areas) and naturally promote team inspiration and creativity.





**Mobile workstations
(optional accessories)**
Black - Timber

**Mobile workstation
(optional accessories)**
Ochre - White



Accessories hook
(optional accessory)



Set of 3 storage compartments
(optional accessory)



White magnetic board
(optional accessory)

Square high meeting tables starter/add-on units with duo bench and duo pedestal
Black - Nebraska



Rectangular high meeting tables starter/add-on units
Black - White

COWORKING

CHARACTERISTICS

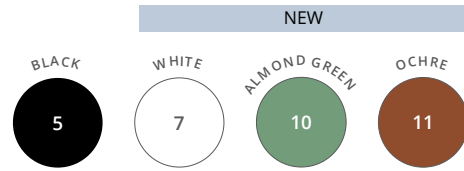

Metal legs finishes



Tops MFC finishes



Download the data sheet



Top

25 mm thick Structorex® melamine-coated tops. 4 40 mm radius rounded corners. 2 mm thick shock-proof ABS edging. 2 mounting heights : H 105 and H 75 cm.

Electrification

Top available in 2 versions : with part drilled cable management or **with electrical equipment** including 1 built-in electrical socket strip, equipped with 3 power outlets + 1 USB A charging socket 5v + 1 USB C charging socket 5v + 1 cable port.



White



Almond Green



Ochre



Mobile workstation

Castors

4 Ø 75 mm lockable castors.



Square high table



Rectangular high table

Dimensions

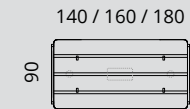

Mobile workstation and rectangular high table bottom view

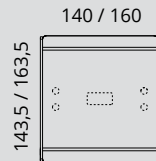

Square high table bottom view

Tops synoptic



Mobile workstation and rectangular high table tops

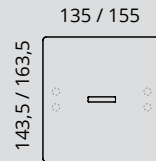

Square high table tops

Legs

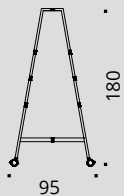

Mobile workstation arch leg



Rectangular high table arch leg

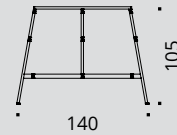

Square high table arch leg

Leg

Metal « A » arch leg, square cross-section 25 x 25 mm, with a transverse bar cross-section 40 x 25 mm. Total height : H 180 cm.

TECHNICAL DESCRIPTION

- 25 mm thick Structorex® melamine-coated tops with 4 40 mm radius rounded corners. 2 mm thick shock-proof ABS edging.
- Mobile workstations and meeting tables available in 2 top versions : with part drilled cable management or with electrical equipment including 1 built-in electrical socket strip, equipped with 3 power outlets + 1 USB A charging socket 5v + 1 USB C charging socket 5v + 1 cable port. 2 m power supply cable included.
- H 180 cm or H 105 cm legs (depending on version), metal « A » arch leg, square cross-section 25 x 25 mm, with transverse bar cross-section 40 x 25 mm. Black lacquered epoxy finish.
- Mobile workstations also available in white (smooth) and almond green or ochre (textured) lacquered epoxy finish.
- Assembly connected by steel structural beams, cross-section 40 x 25 mm, same finishes as the legs.
- Options available : set of 3 storage compartments, whiteboard, accessories hook, upper compartment, bench, pedestal, extensions depending on version, fitted on the structure.
- Mobile workstations : 4 Ø 75 mm lockable castors on H 180 cm leg. High tables : adjustable screw feet on H 105 cm leg to compensate for any unevenness in the floor (10 mm range).

BLACK



— Metal legs finish —

NEBRASKA



TIMBER



WHITE



— Tops MFC finishes —

Mobile WORKSTATIONS

WITH PART DRILLED CABLE MANAGEMENT

Tops equipped with 2 Ø 80 mm part drilled cable ports and 1 double opening Top Access hatch



WITH ELECTRICAL EQUIPMENT

Tops equipped with 1 built-in electrical socket strip (3 power outlets + USB A/C) and 2 Ø 80 mm part drilled cable ports

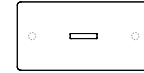

	Dim. (cm)		Ref.	Top finish		Ref.	Top finish
Mobile workstations H 75 - 105 cm High legs H 180 cm and 4 lockable castors	D 90 / L 140		DX235	+ <input type="checkbox"/>		DY075	+ <input type="checkbox"/>
	D 90 / L 160		DX245	+ <input type="checkbox"/>		DY085	+ <input type="checkbox"/>
	D 90 / L 180		DX255	+ <input type="checkbox"/>		DY095	+ <input type="checkbox"/>

NEW

«D end» extension

For fixing on legs with brackets (right or left mounting)
D 35 cm

L 90 cm



DY235

+

► Options

	Description	Ref.	Finish
Set of 3 storage compartments Black metal D 12 / H 12 / L 55-65-75 cm	<p>For fixing on the H 180 cm leg</p>	DX295G	● Black
Upper storage compartment D 24 / H 15 cm Sits on the top beam of the workstation	<p>L 137,5 cm for L 140 cm workstation L 157,5 cm for L 160 cm workstation L 177,5 cm for L 180 cm workstation</p>	DX323 DX333 DX343	+ <input type="checkbox"/> + <input type="checkbox"/> + <input type="checkbox"/>
White magnetic board White metal H 40 / L 70 cm	<p>For fixing on the H 180 cm leg</p>	DX317S	○ White
Accessories hooks for helmet, bag, coat	<p>Set of 2 For fixing on H 105 / H 180 cm legs</p>	DT035G	● Black





Mobile WORKSTATIONS

NEW

WITH PART DRILLED CABLE MANAGEMENT

Tops equipped with 2 Ø 80 mm part drilled cable ports and 1 double opening Top Access hatch



WITH ELECTRICAL EQUIPMENT

Tops equipped with 1 built-in electrical socket strip (3 power outlets + USB A/C) and 2 Ø 80 mm part drilled cable ports

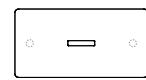

	Dim. (cm)		Ref.	Leg finish	Top finish		Ref.	Leg finish	Top finish
Mobile workstations H 75 - 105 cm High legs H 180 cm and 4 lockable castors	D 90 / L 140		DX23	+ <input type="checkbox"/>	+ <input type="checkbox"/>		DY07	+ <input type="checkbox"/>	+ <input type="checkbox"/>
	D 90 / L 160		DX24	+ <input type="checkbox"/>	+ <input type="checkbox"/>		DY08	+ <input type="checkbox"/>	+ <input type="checkbox"/>
	D 90 / L 180		DX25	+ <input type="checkbox"/>	+ <input type="checkbox"/>		DY09	+ <input type="checkbox"/>	+ <input type="checkbox"/>

«D end» extension For fixing on legs with brackets (right or left mounting) D 35 cm	L 90 cm		DY23	+ <input type="checkbox"/>	+ <input type="checkbox"/>
---	---------	--	------	----------------------------	----------------------------

► Options

	Description	Ref.	Finish
Set of 3 storage compartments Black metal D 12 / H 12 / L 55-65-75 cm		DX297S	<input type="radio"/> White
		DX2910R	<input type="radio"/> Almond Green
		DX2911W	<input type="radio"/> Ochre
Double opening Top Access hatch For tables with part drilled cable management		DU135G	<input type="radio"/> Black
		DU137S	<input type="radio"/> White
Universal single metal cable tray For tables with part drilled cable management D 12 / H 9 / L 60 cm Internal H 8 cm		DP045G	<input type="radio"/> Black
		DP047S	<input type="radio"/> White





Square MEETING TABLES

WITH PART DRILLED CABLE MANAGEMENT



Tops equipped with 4 Ø 80 mm part drilled cable ports and 1 double opening Top Access hatch

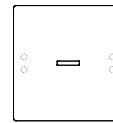

WITH ELECTRICAL EQUIPMENT

Tops equipped with 1 built-in electrical socket strip (3 power outlets + USB A/C) and 4 Ø 80 mm part drilled cable ports

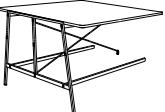
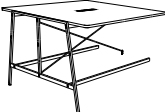

	Dim. (cm)		Ref.	Top finish		Ref.	Top finish
Square high tables H 105 cm Starter unit High legs H 105 cm	D 143,5 / L 140 (seats 4/6)		DT785	+ <input type="checkbox"/>		DU425	+ <input type="checkbox"/>
	D 163,5 / L 160 (seats 6/8)		DT795	+ <input type="checkbox"/>		DU435	+ <input type="checkbox"/>
Square high tables H 105 cm Add-on unit High leg H 105 cm	D 143,5 / L 140 (seats 4)		DT805	+ <input type="checkbox"/>		DU445	+ <input type="checkbox"/>
	D 163,5 / L 160 (seats 4)		DT815	+ <input type="checkbox"/>		DU455	+ <input type="checkbox"/>

NEW

► Extensions

«D end» extensions

For fixing on legs with brackets (right or left mounting)
D 35 cm



L 143,5 cm
L 163,5 cm

DY245
DY255

+
+





Rectangular MEETING TABLES

WITH PART DRILLED CABLE MANAGEMENT

Tops equipped with 2 Ø 80 mm part drilled cable ports and 1 double opening Top Access hatch



WITH ELECTRICAL EQUIPMENT

Tops equipped with 1 built-in electrical socket strip (3 power outlets + USB A/C) and 2 Ø 80 mm part drilled cable ports

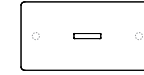

	Dim. (cm)		Ref.	Top finish		Ref.	Top finish
Rectangular high tables H 105 cm Starter unit High legs H 105 cm	D 90 / L 140		DT865	+		DU465	+
	D 90 / L 160		DT875	+		DU475	+
	D 90 / L 180		DT885	+		DU485	+
Rectangular high tables H 105 cm Add-on unit High leg H 105 cm	D 90 / L 140		DT895	+		DU495	+
	D 90 / L 160		DT905	+		DU505	+
	D 90 / L 180		DT915	+		DU515	+

NEW

► Extension

«D end» extension

For fixing on legs with brackets (right or left mounting)
D 35 cm



Dim. (cm)

L 90 cm

Ref.

DY235

Top finish

+

► Options

Double opening Top Access hatch

For tables with part drilled cable management

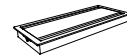

Description

D 14,8 / L 31,6 cm

Ref.

DU135G

Finish

Black

Universal single metal cable tray

For tables with part drilled cable management
D 12 / H 9 / L 60 cm
Internal H 8 cm

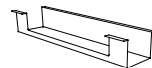

To be fixed directly under the tops with wood screws

Ref.

DP045G

Finish

Black

UK cable port power module

UK power socket + 1 USB A socket 5v
With a 2 m power supply cable



Ø 100 mm
Fitted into the part drilled cable ports Ø 80 mm

Ref.

DR995G

Finish

Black

